

PowerTech™ PVS 6068HFG08 Diesel Engine

Generator Drive Engine Specifications



6068HFG08 shown

Engine dimensions

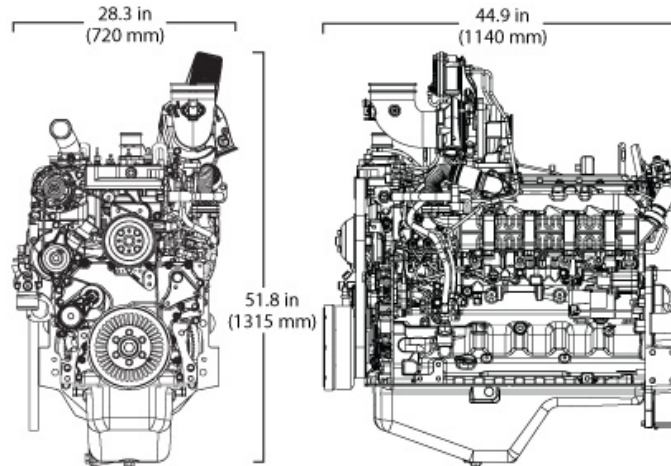

Dimensions may vary according to options selected. Call your distributor for more information.

Certifications

CARB
EPA Tier 4
EU Stage IV

General data

Model	6068HFG08	Length – mm (in) to rear of block	1140 (44.9)
Number of cylinders	6	Width – mm (in)	720 (28.3)
Displacement – L (cu in)	6.8 (415)	Height – mm (in)	1315 (51.8)
Bore and Stroke – mm (in)	106 x 127 (4.2 x 5.0)	Weight, dry – kg (lb)	770 (1698)
Engine Type	In-line, 4-cycle		
Aspiration	Turbocharged and air-to-air aftercooled		

Performance data range

Rated speed Hz (rpm)	Engine power				Generator efficiency %	Rated fan power		Power factor	Calculated generator set output			
	Prime		Standby			kW	hp		Prime		Standby	
	kW	hp	kW	hp					kWe*	kVA	kWe	kVA
60 (1800)	136–164	183–219	150–180	201–241	90	9.0–10.8	12.1–14.5	0.8	114–138	143–172	127–152	159–190

Prime power is the nominal power an engine is capable of delivering with a variable load for an unlimited number of hours per year. This rating conforms to ISO3046 and SAE J1995.

Standby power as defined in ISO 8528-1 is the maximum engine power available at varying load factors for up to 200 hours per year. This rating conforms to ISO 3046 and SAE J1995. The calculated generator set rating range for standby applications is based on minimum engine power (nominal -5 percent) to provide 100 percent meet-or-exceed performance for assembled standby generator sets.

*Electrical power is calculated from the typical generator efficiency and fan power percentages shown. Applications may vary.

Exhaust filter dimensions

Size	4	5
Diameter – mm (in)	320.04 (12.6)	304.8 (12)
Length – mm (in)	635 (25)	906.78 (35.7)
Weight – kg (lb)	30.84 (68)	30.84 (68)

See your John Deere Power Systems engine distributor for more information on available filter size options.

Features and benefits

Variable geometry turbocharger (VGT)

- Varies exhaust pressure based on load and speed to ensure proper EGR flow. The combination of the cooled EGR and VGT provide low-speed torque, quicker transient response, higher-peak torque, and world-class fuel economy.

Cooled exhaust gas recirculation (EGR)

- EGR cools and mixes measured amounts of cooled exhaust gas with incoming fresh air to lower peak combustion temperatures, thereby reducing NOx.

Exhaust filters

- These engines utilize a catalyzed exhaust filter that contains a diesel oxidation catalyst (DOC) and a diesel particulate filter (DPF). This system delivers premium load acceptance characteristics. The DOC reacts with exhaust gases to reduce carbon monoxide, hydrocarbons, and some particulate matter (PM). The downstream DPF traps and holds the remaining PM. Trapped particles are oxidized within the DPF through a continuous cleaning process called passive regeneration. Passive regeneration occurs during normal operating conditions when heat from the exhaust stream and catalysts within the exhaust filter trigger the oxidation of the trapped PM. If passive regeneration cannot be achieved due to low temperature, load, or speed, then PM is removed using active regeneration — an automatic cleaning process controlled by the exhaust temperature management system.

Selective catalytic reduction (SCR)

- John Deere engines feature an SCR system that utilizes a urea-based additive, sometimes referred to as diesel exhaust fluid (DEF). The ammonia in the urea mixes with engine exhaust gases in the SCR catalyst to reduce NOx — converting it to nitrogen and water vapor.

High-pressure common-rail (HPCR) and engine control unit (ECU)

- The HPCR fuel system provides variable common-rail pressure, multiple injections, and higher injection pressures up to 2,500 bar (36,000 psi). It also controls fuel injection timing and provides precise control for the start, duration, and end of injection.

SCR catalyst dimensions

Size	4	5
Diameter – mm (in)	322.58 (12.7)	360.68 (14.2)
Length – mm (in)	774.7 (30.5)	784.86 (30.9)
Weight – kg (lb)	39.01 (86)	47.17 (104)

4-valve cylinder head

- The 4-valve cylinder head provides excellent airflow resulting in greater low-speed torque and better transient response time by utilizing a cross-flow design and a U-flow design.

Air-to-air aftercooled

- This is the most efficient method of cooling intake air to help reduce engine emissions while maintaining low-speed torque, transient response time, and peak torque. It enables an engine to meet emissions regulations with better fuel economy and the lowest installed costs.

Compact size

- Lower installed cost
- Mounting points are the same as previous engine models

John Deere electronic engine controls

- Faster engine control unit (ECU) manages both the engine and the exhaust filter
- Four times the memory, twice the RAM and double the processing speed
- The input/output capability has increased 40%
- Premium software option integrates with equipment or vehicles to reduce engineering and installation costs

Additional features

- Glow plugs
- Gear-driven auxiliary drive
- 500 hour oil change
- Self adjusting poly-vee fan drive
- Optional factory installed variable speed fan drive improves fuel economy and reduces noise levels
- RH and LH engine mounted fuel filters
- Replaceable (wet) cylinder liners
- Low pressure fuel system with electrical transfer pump and “auto prime” feature

John Deere Power Systems
3801 W. Ridgeway Ave.
PO Box 5100
Waterloo, IA 50704-5100
Phone: 800.553.6446
Fax: 319.292.5075

John Deere Power Systems
Usine de Saran
La Foulonnerie - B.P. 11.13
45401 Fleury les Aubrais Cedex
France
Phone: 33.2.38.82.61.19
Fax: 33.2.38.82.60.00

All values at rated speed and power with standard options unless otherwise noted. Specifications and design subject to change without notice.